

SPL03-001

Digital differential pressure sensor

Restricted

1. Security warning

The information contained in this document is the exclusive property of GoerTek Inc. and should not be disclosed to any third party without the written consent of GoerTek Inc.

2. Publication history

Version	Date	Description	Author	Approved
1.0	2018.09.29	New design	Wiming	Devin
2.0	2019.02.18	Add OPC instruction	Wiming	Devin
3.0	2019.04.02	Update Figure 5 and Table 13	Wiming	Devin
4.0	2019.09.07	Updated Parameter	Serena	Devin

Index of Contents

1. Introduction	4
2. Test condition	5
3. Absolute maximum ratings	5
4. Electrical characteristics	5
5. Operation	6
5.1 Operating Modes	6
5.2 Measurement Flow	7
5.2.1 Pressure Measurement	8
5.2.2 Temperature Measurement	9
5.3 Sensor Interface (I2C)	10
5.4 Interrupt	11
5.5 Calibration and Measurement Compensation	11
5.5.1 How to Calculate Compensated Pressure Values	12
5.5.2 How to Calculate Compensated Temperature Values	12
5.5.3 How to Calculate Interrupt Pressure Value	12
6. Applications	13
7. Register Map	14
7.1 Read-only registers	15
7.2 Write-only registers (command)	16
7.3 Read-Write registers	16
8. Mechanical characteristics	18
8.1 Pin configuration	18
8.2 Outline dimensions	19
9. Storage and transportation	20
10. Soldering recommendation	20
11. Package specifications	21

1. Introduction

The SPL03-001 is a miniaturized Digital Gauge Pressure Sensor with a high accuracy and a low current consumption. The SPL03-001 is both a pressure and a temperature sensor. The pressure sensor element guarantees a high precision during temperature changes. The small package makes the SPL03-001 ideal for any devices. The SPL03-001's internal signal processor converts the output from the pressure and temperature sensor elements to 24-bit results. Each pressure sensor has been calibrated individually and contains calibration coefficients. The coefficients are used in the application to convert the measurement results to true pressure and temperature values.

Key features

- Gauge Pressure range: -20 ... 20KPa
- Temperature Range: 0...+70°C
- Supply voltage: 1.7 ... 3.6V (VDD), 1.2 ... 3.6V (VDDIO)
- Absolute accuracy: typ. ± 0.1 KPa (-20~20KPa), typ. ± 0.012 KPa (-2~2KPa),
- Temperature accuracy: $\pm 2^\circ\text{C}$ (0~70°C)
- Pressure temperature sensitivity: $< 1\text{Pa/K}$
- Measurement time: Typical: 4 ms
- Average current consumption: 3 μA , Standby current: 100nA
- I2C interface, Embedded 24-bit ADC
- Pb-free, halogen-free and RoHS compliant

Typical applications

- Electronic cigarette
- Flowing rate test

Specific notes

Particles can influence the performance of the pressure sensor, we strongly recommend you to introduce special measures to avoid deposition of particles on the MEMS membrane or screen particles after assembly as the assembly process is considered to be the main root cause for particle generation.

2. Test condition

Table 1: Test condition

Standard Conditions	Temperature	Humidity	Pressure
Environment conditions	-40°C...+85°C	25%RH...75%RH	-20KPa...20KPa
Basic test conditions	+25°C	60%RH...70%RH	-20KPa...20KPa

3. Absolute maximum ratings

Table 2: Absolute maximum ratings

Parameter	Condition	Min	Max	Units
Storage temperature		-40	+125	°C
Supply Voltage	All pins	-0.3	+3.63	V
Voltage at all IO Pins	All pins	-0.3	+3.63	V
ESD rating	JESD22-A114	-2	+2	kV
Overpressure		-80	80	KPa

4. Electrical characteristics

VDD = 1.8V, VDDIO=1.8V, T=25°C, unless otherwise noted. If not stated otherwise, the given values are ± 3 -Sigma values over temperature/voltage range in the given operation mode.

Table 3: Operating conditions, output signal and mechanical characteristics

Parameter	Symbol	Condition	Min	Typ. ⁽¹⁾	Max	Units
Operating temperature	TA	Operational	-40	25	85	°C
		Full accuracy	0	25	70	°C
Operating Pressure	P		-20		20	KPa
Supply voltage	VDD		1.7		3.6	V
Interface supply voltage	VDDIO		1.2		3.6	V
Supply current	I _{dd}	1 Hz (with 1 measurement per second.)		2.8	3	uA
Peak current	I _{peak}	During conversion		0.9	1.15	mA
Standby current	I _{dds}			5	100	nA

Absolute accuracy pressure	P_A	-2~2KPa 0...+70°C after OPC ⁽²⁾		±0.012		KPa
		-20~20KPa 0...+70°C after OPC ⁽²⁾		±0.1		KPa
Noise in pressure	P_Noise			3		PaRMS
Offset temperature coefficient	TCO	0 KPa +25...+40°C		±1		Pa/K
Absolute accuracy temperature		0~+70°C		±2		°C
Pressure/Temperature measurement rate	f		0.25		128	Hz
Pressure measurement time	t			4		ms
Serial data clock	f _{I2C}	For I2C			3.4	MHz

Note: (1) Typical specifications are not guaranteed.

(2) OPC: One point calibration.

5. Operation

5.1 Operating Modes

The SPL03-001 supports three operation condition modes. User can have the highest flexibility from selecting a high number of possible combinations of the chip settings, such as output data rate, with these operation modes.

Three operation mode:

- Standby mode
- Oneshot mode
- Periodic mode

In standby mode, this is the default mode after power on. No measurements are performed. All registers values can be accessible.

Oneshot mode, it is a single measurement. When this mode is enabled, one pressure measurement is performed after one temperature measurement according to the selected precision and it will return to the standby mode after the measurement is finished. If a next measurement is needed, the oneshot mode must be selected again. This is suitable for low sampling rate required application or host-based synchronization.

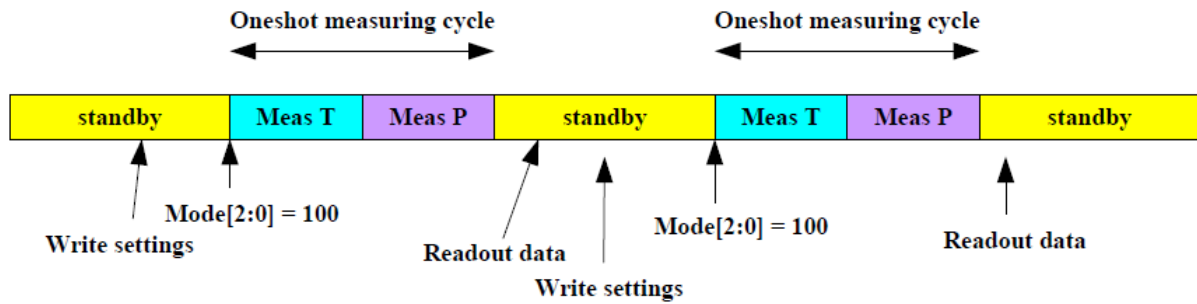

Figure 1: Oneshot mode

Periodic mode, pressure and temperature measurement are performed cyclically continuously according to the selected measurement rate and precision. It is comprised by an active measurement period and an inactive standby period. The measured temperature and pressure results can be accessible in each standby period during the periodic measurement cycle.

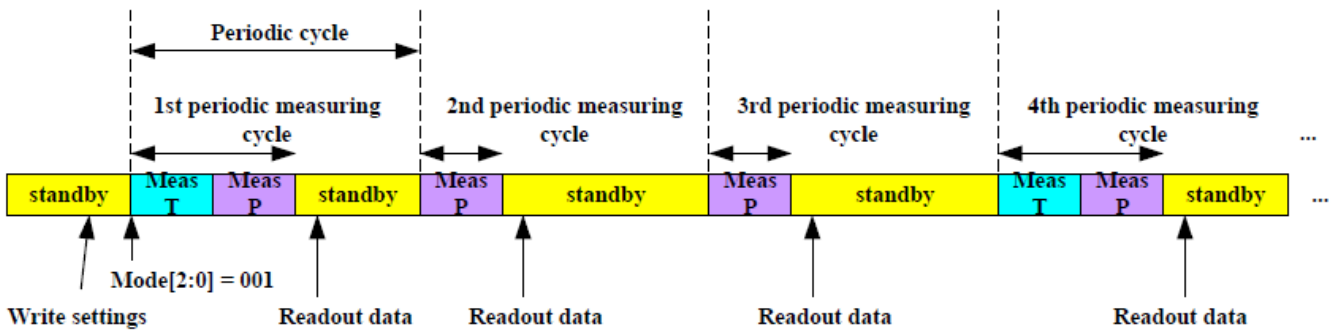

Figure 2: Periodic mode

5.2 Measurement Flow

When SPL03-001 is enabled to measure data, it will start to perform temperature and pressure or only pressure measurement. An interrupt can be generated or the status flags will be shown in the registers if readout data is ready. After measurement finished, SPL03-001 can enter into standby mode by itself or by host informing a sleep mode command.

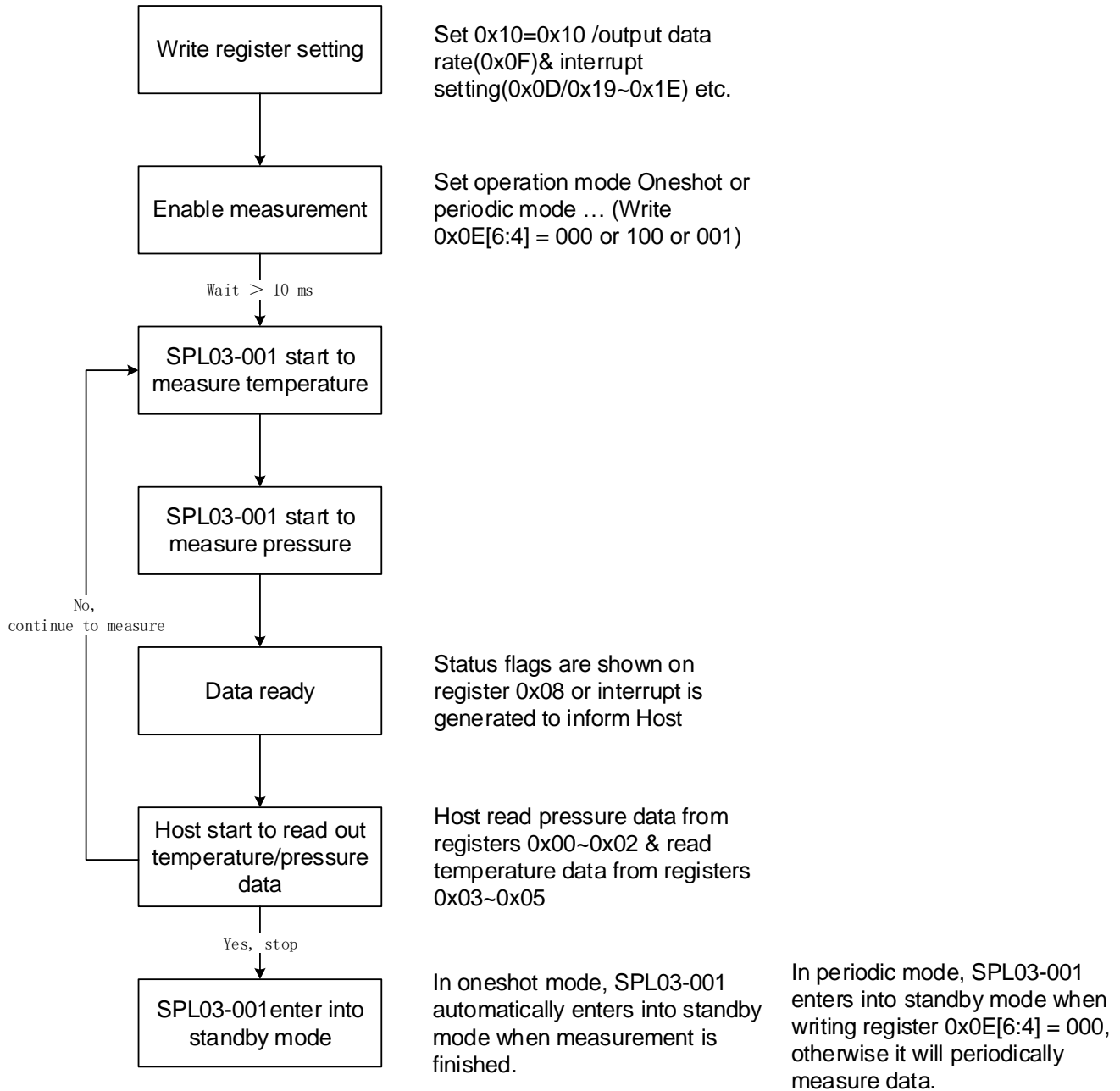

Figure 3: Measurement flow

5.2.1 Pressure Measurement

Pressure measurement is always enabled when SPL03-001 is enabled to measure data. When enabled, the pressure output data rate can be chosen from 0.25 to 128Hz by setting [7:4] bits of output data rate control register (0x0F).

Table 4: Output data rate control register (0x0F)

[7:4]	Output data rate of pressure data
0010	128 Hz
0011	64 Hz
0100	32 Hz
0101	16 Hz
0110	8 Hz
0111	4 Hz
1000	2 Hz
1001	1 Hz
1010	0.5Hz
1011	0.25Hz

5.2.2 Temperature Measurement

When setting bit [3] of output data rate control register (0x0F) to be “1”, the temperature measurement can be skipped otherwise it is enabled. When enabled, the output data rate of temperature data is not directly controlled by register bit setting. The bits [3:0] of register 0x0F define the pressure to temperature ratio. It is to be used with the output data rate of pressure data in bits [7:4] of register 0x0F to have the output data rate for temperature data. For example, when output data rate of pressure data is chosen as 8Hz, while P/T ratio is selected as 8. That means the output data rate of temperature is 1Hz.

Table 5: Output data rate control register (0x0F)

[3:0]	P/T ratio
0000	1
0001	2
0010	4
0011	8
0100	16
0101	32
0110	64
1xxx	No temperature

5.3 Sensor Interface (I2C)

I2C supports standard ($\leq 100\text{KHz}$), fast ($\leq 400\text{KHz}$) and high speed ($\leq 3.4\text{MHz}$) modes. If I2C is to be used, CSB pin should be ensured that it is already connected to VDDIO high level during power-on-reset of SPL03-001. This ensures correct protocol detection and avoids inadvertent data decoding.

The digital interface supports 3 kinds of transactions:

- Single byte write
- Single byte read
- Multiple byte read (single register address and multiple data read with auto-incremented address)

SDO should be connected to VDDIO, the address is 1110001(0x71). This SDO pin should not be left floating, it will make I2C device address undefined.

I2C write

When master sends I2C with RW bit (bit 0 of I2C device address byte) equal to '0', I2C is in writing operation. Then master sends pairs of register address and register data to SPL03-001. The transaction will be end if a stop condition is sent by master.

Single byte write is depicted in figure, multiple bytes write is not address auto-incremented

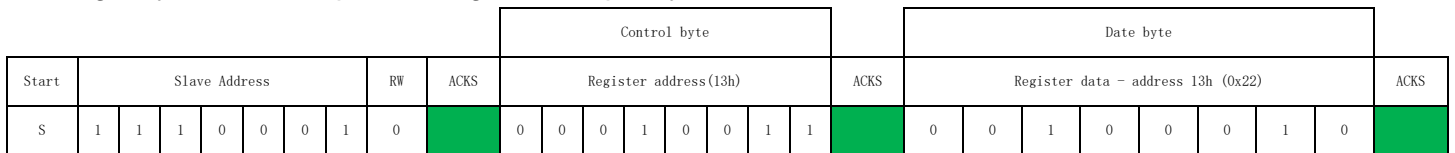

I2C read

SPL03-001 supports register address auto-incremented. When master sends the first register address to SPL03-001, SPL03-001 will output sequential data until a no-ack and stop condition occurs. The transaction is depicted in the figure



5.4 Interrupt

SPL03-001 can generate an interrupt when the corresponding event is triggered. The interrupt trigger source is pressure data ready, pressure data larger/lower than predefined threshold. SPL03-001 uses the SDO pin for the interrupt signal.

SDO acts as an output pin when interrupt is enabled and I2C read/write is not processing.

(Note 1: refer to interrupt control register (0x0Dh))

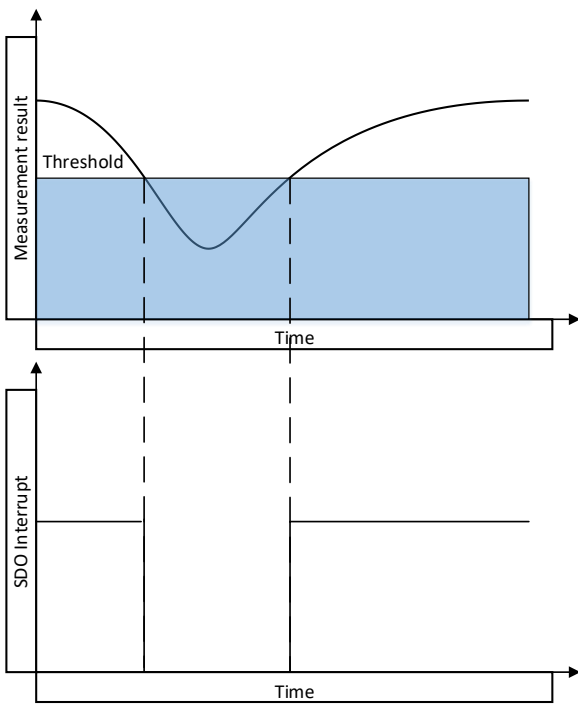

Interrupt mode 1: data<threshold (0x0D=0x02)

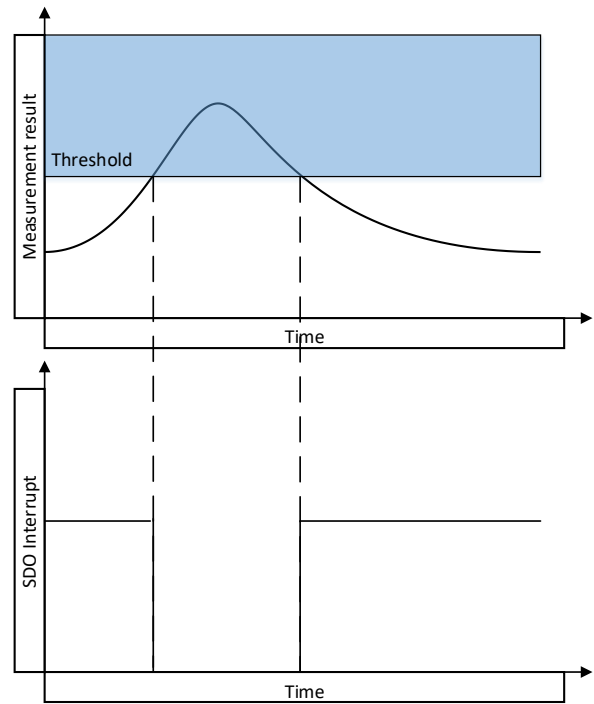

Interrupt mode 2: data>threshold (0x0D=0x04)

5.5 Calibration and Measurement Compensation

The SPL03-001 is a calibrated sensor. These are used in the application (for instance by the host processor) to compensate the measurement results for sensor non-linearity's.

The sections that follow, describe how to calculate the compensated results and convert them into kPa and °C values.

5.5.1 How to Calculate Compensated Pressure Values

1. Read the pressure result from the registers (0x00~0x02).
2. Convert to decimal P_{raw}.
3. Calculate pressure value P (kPa)

$$P_{(kPa)} = \frac{P_{raw}}{2^{24}} * 50 - 25$$

5.5.2 How to Calculate Compensated Temperature Values

1. Read the temperature result from the registers (0x03~0x05).
2. Convert to decimal T_{raw}.
3. Calculate temperature value T (°C)

$$T_{(°C)} = \frac{T_{raw}}{2^{24}} * 125 - 40$$

5.5.3 How to Calculate Interrupt Pressure Value

1. Calculate interrupt pressure value rawdata P_{raw}

$$P_{(raw)} = \frac{P_{(kPa)} + 25}{50} * 2^{22}$$

2. Convert to Binary P_{raw}.
3. Write P_{raw} to 0x19~0x1B (Upper threshold) or 0x1C~0x1E (Lower threshold)

6. Applications

The example application circuit example uses the I2C serial interface with interrupt.

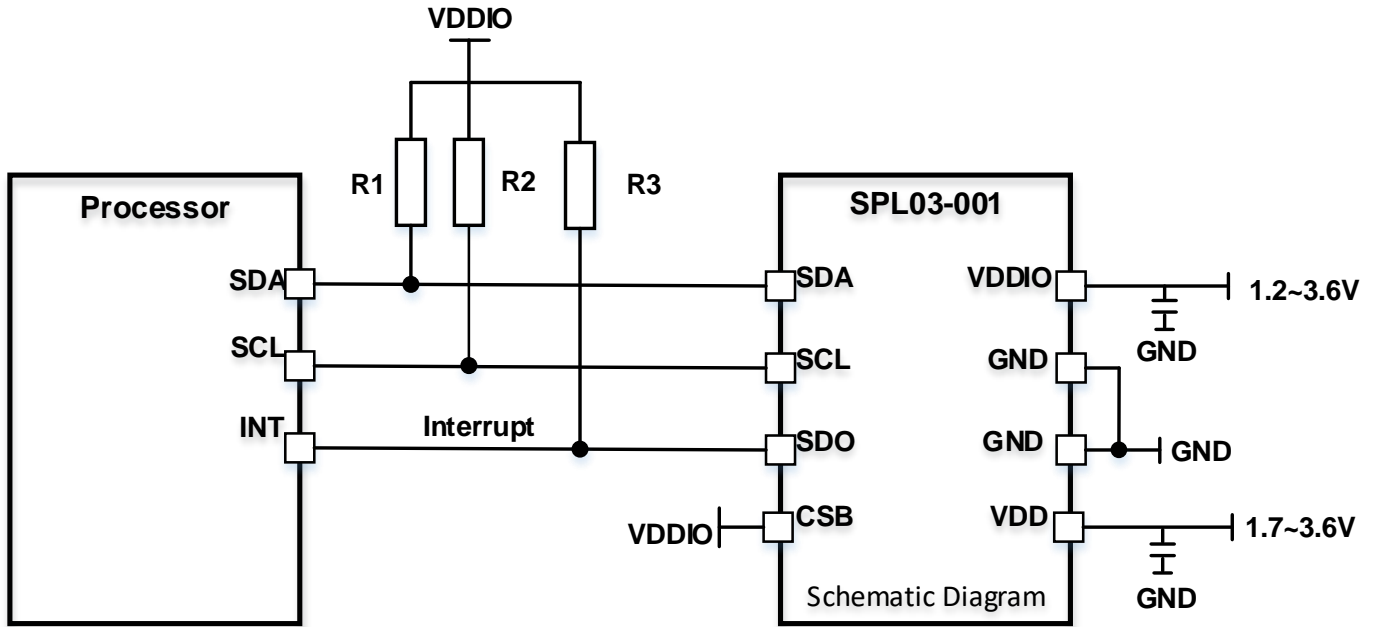

Figure 4: Typical application circuit

Table 6 Component Values

Component	Symbol	Values			Unit	Note / Test Condition
		Min.	Typ.	Max.		
Pull-up/down Resistor	R1, R2		5		KΩ	
	R3		3.3		KΩ	
Supply Blocking Capacitor	C1, C2	100	100		nF	The blocking capacitors should be placed as close to the package pins as possible.

7. Register Map

Table 7 Register Map

Byte	Name	Description	Type	B7	B6	B5	B4	B3	B2	B1	B0	Default
00H	PSR2	Pressure data reading MSB	R	PSR[23:16]								00H
01H	PSR1	Pressure data reading LSB	R	PSR[15:8]								00H
02H	PSR0	Pressure data reading XLSB	R	PSR[7:0]								00H
03H	TMR2	Temperature data reading MSB	R	TMR[23:16]								00H
04H	TMR1	Temperature data reading LSB	R	TMR[15:8]								00H
05H	TMR0	Temperature data reading XLSB	R	TMR[7:0]								00H
08H	STAX	Chip status flag	R	STA[7:0]								00H
09H	IDX	Chip ID and revision ID	R	CID[3:0]				RID[3:0]				14H
0DH	INTX	Interrupt control	RW	INT[7:0]								00H
0EH	MODX	Mode control	RW	MOD[3:0]				NR				00H
0FH	ODRX	Output data rate control	RW	PODR[3:0]				PTR[3:0]				90H
19H	USH2	Upper threshold MSB	RW	USH[23:16]								20H
1AH	USH1	Upper threshold LSB	RW	USH[15:8]								00H
1BH	USH0	Upper threshold XLSB	RW	USH[7:0]								00H
1CH	LSH2	Lower threshold MSB	RW	LSH[23:16]								00H
1DH	LSH1	Lower threshold LSB	RW	LSH[15:8]								01H
1EH	LSH0	Lower threshold XLSB	RW	LSH[7:0]								00H

7.1 Read-only registers

[Output data]

The pressure sensor and temperature sensor data reading is 24bit unsigned values, ranging from 0 to FF-FF-FFH.

Table 8: Data output reading registers

Byte	Bit	Name	Type	Description	Default
00H,01H,02H		PSR	R	Pressure data reading	00-00-00H
03H,04H,05H		TMR	R	Temperature data reading	00-00-00H

[Configurations]

Table 9: Chip configuration registers

Byte	Bit	Name	Type	Description	Default
08H	[7:0]	STA [7] [6] [5] [4] [3] [2] [1] [0]	R	Status flag indicator: Booting flag: 0: Booting now; 1: Boot process done Reserved Reserved Reserved Reserved Over threshold: 0: Data in-bound; 1: Data> threshold; Under threshold: 0: Data in-bound; 1: Data< threshold; Data ready: 0: Measuring; 1: Data ready	00H
09H	[7:0]	RID[3:0]	R	Revision ID:	14H

(*The status bits of register 0x08h will be cleared when a read of status register 0x08h is performed.)

7.2 Write-only registers (command)

[Software reset]

Table 10: Software reset

Byte	Bit	Name	Type	Description	Default
0CH	[7:0]	RST[7:0]	W	Software reset for whole chip: '10100101': Reset whole chip 'XXXXXXXX1': Reset FIFO	--

7.3 Read-Write registers

[Interrupt control]

Table 11: Interrupt control

Byte	Bit	Name	Type	Description	Default
0DH	[7]	INT	RW	Interrupt control: Reserved Reserved	00H
	[7]			Reserved	
	[6]			Reserved	
	[5]			Reserved	
	[4]			Reserved	
	[3]			Reserved	
	[2]			If data> threshold: 0: Do not act; 1: Generate INT;	
	[1]			If data< threshold: 0: Do not act; 1: Generate INT;	
	[0]			If data is ready: 0: Do not act; 1: Generate INT;	

(*Interrupt will not really output to SDO pin if the interrupt is not enabled in OTP memory.)

(*The interrupt will be cleared when a read of status register 0x08h is performed.)

[System control]

Table 12: System control

Byte	Bit	Name	Type	Description	Default
0EH	[7]	ROW	RW	Output row data: 0= Calibrated data 1= Get row data;	0
0EH	[6:4]	MOD[2:0]	RW	Operation mode: 000: Sleep mode 001: Periodic 100: One shot	000
0EH	[3:0]	(Reserved)	RW		0000
0FH	[7:4]	PODR[3:0]	RW	Output data rate of pressure sensor: 0010:128 Hz 0011:64 Hz 0100:32 Hz 0101:16 Hz 0110:8 Hz 0111:4 Hz 1000:2 Hz 1001:1 Hz 1010:0.5Hz 1011:0.25Hz	1001
0FH	[3:0]	PTR[3:0]	RW	Output data rate ratio between (P/T): bit[3] is reserved 0000: 1 0100: 16 0001: 2 0101: 32 0010: 4 0110: 64 0011: 8 1xxx: No temperature	0000
19H~1BH	[7:0]	USH	RW	Upper threshold	20-00-00H
1CH~1EH	[7:0]	LSH	RW	Lower threshold	00-01-00H

8. Mechanical characteristics

8.1 Pin configuration

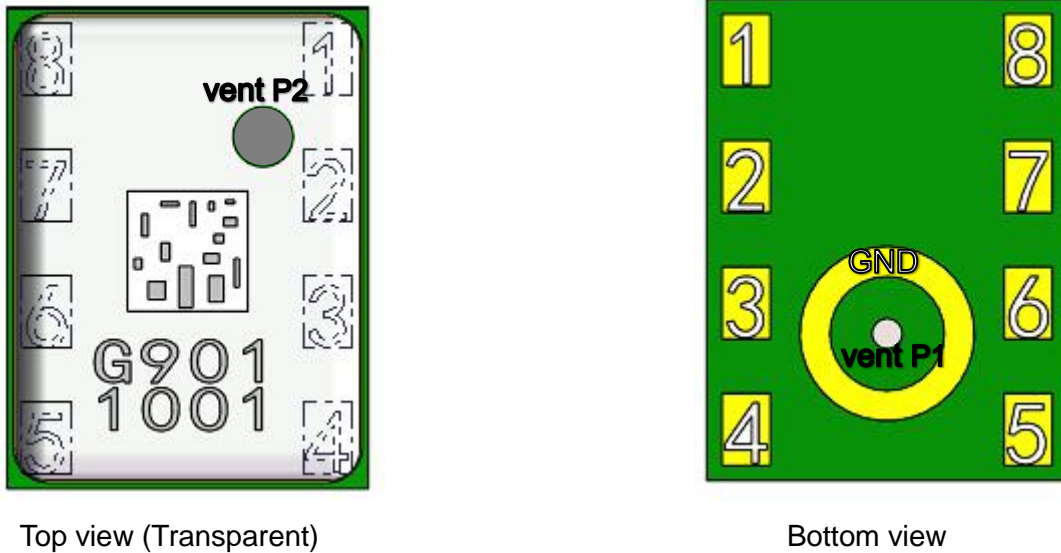

Top view (Transparent)

Bottom view

Figure 5: Layout pin configuration SPL03-001 (bottom view and top view)

Note: When $P1 > P2$, the sensor output > 0 . When $P1 < P2$, the sensor output < 0 .

Table 13: Pin configuration of SPL03-001

Pin	Name	I2C
1	SCL	Serial Clock
2	SDA	Serial data in/out
3	CSB	Connect to VDDIO
4	GND	Ground
5	GND	Ground
6	SDO	Serial Data Output / Interrupt
7	VDD	Supply voltage for analog blocks
8	VDDIO	Digital supply voltage for digital blocks and I/O interface

8.2 Outline dimensions

The sensor is an 8-pin metal housing LGA $3 \times 4 \times 1.1 \text{ mm}^3$ package. Its dimensions are depicted in Figure 4. General tolerances are $\pm 0.05 \text{ mm}$.

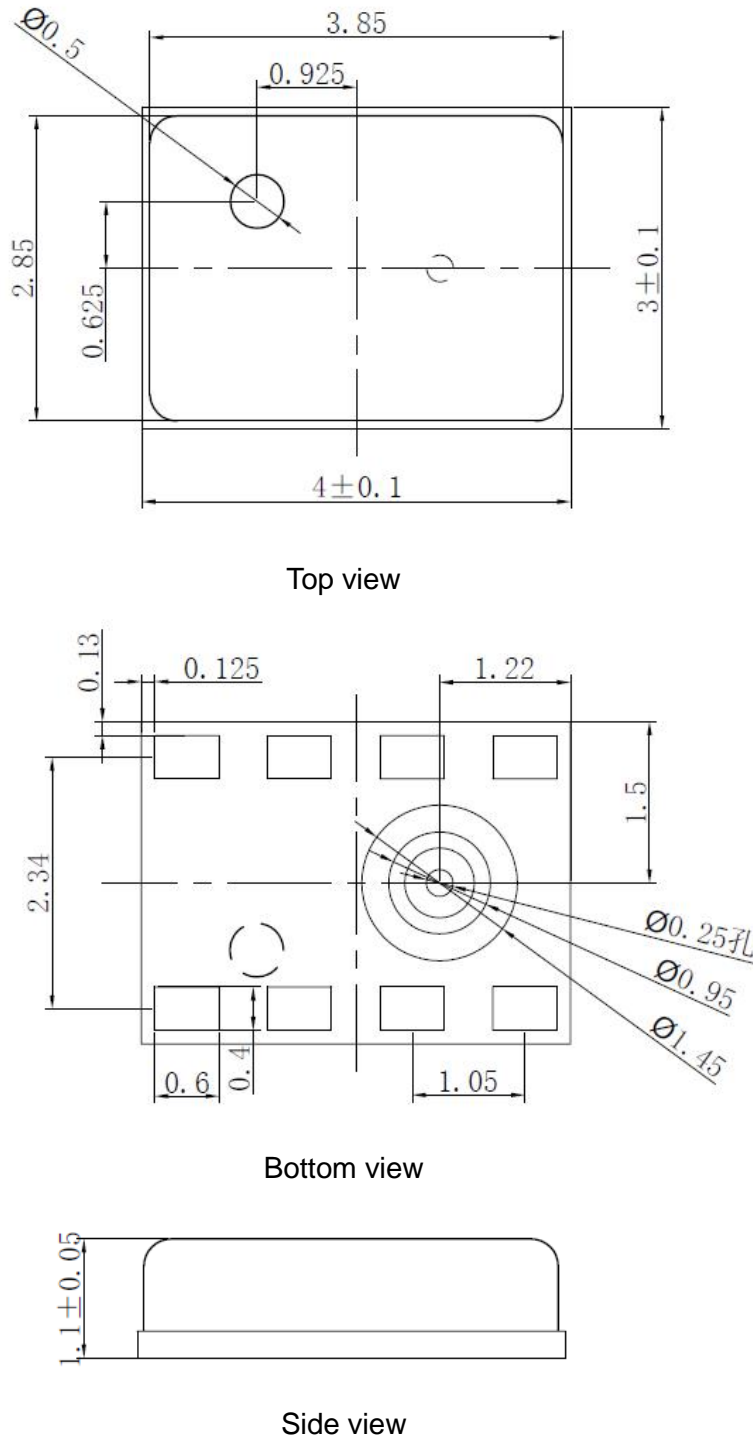

Figure 6: SPL03-001 outline and mechanical data

9. Storage and transportation

- Keep in warehouse with less than 75% humidity and without sudden temperature change, acid air, any other harmful air or strong magnetic field.
- The MEMS pressure sensor with normal pack can be transported by ordinary conveyances. Please protect products against moist, shock, sunburn and pressure during transportation.
- Storage Temperature Range: $-40^{\circ}\text{C}\sim+125^{\circ}\text{C}$
- Operating Temperature Range: $-40^{\circ}\text{C}\sim+85^{\circ}\text{C}$

10. Soldering recommendation

Recommended solder reflow for flex board:

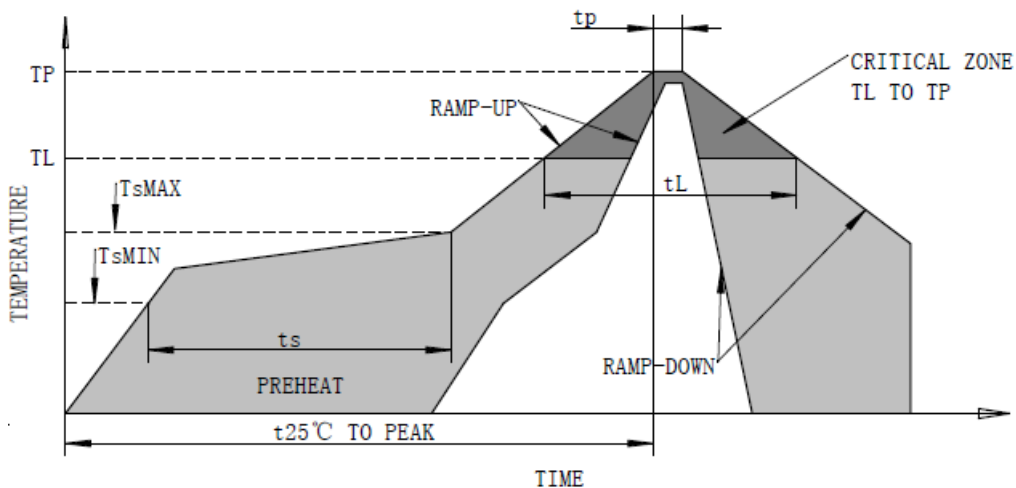

Profile Feature	Pb-Free Assembly
Average ramp-up rate(TsMAX to TP)	2°C /seconds max
Preheat	
-Temperature Min.(TsMIN)	130°C
-Temperature Max.(TsMAX)	200°C
-Time(TsMIN to TsMAX)(Ts)	90~110 seconds
Time maintained above:	
-Temperature(TL)	217°C
-Time(tL)	50~60 seconds
Ramp time of Ts to TL	15-25 seconds
Time 25°C to peak temperature	300 seconds max
Peak temperature(TP)	235-240 °C
Ramp-down rate (peak to 217°C)	2~4°C /seconds

11. Package specifications

Carrier Tape Information [Unit: mm]

Quantity per reel: 5.0 kpcs.

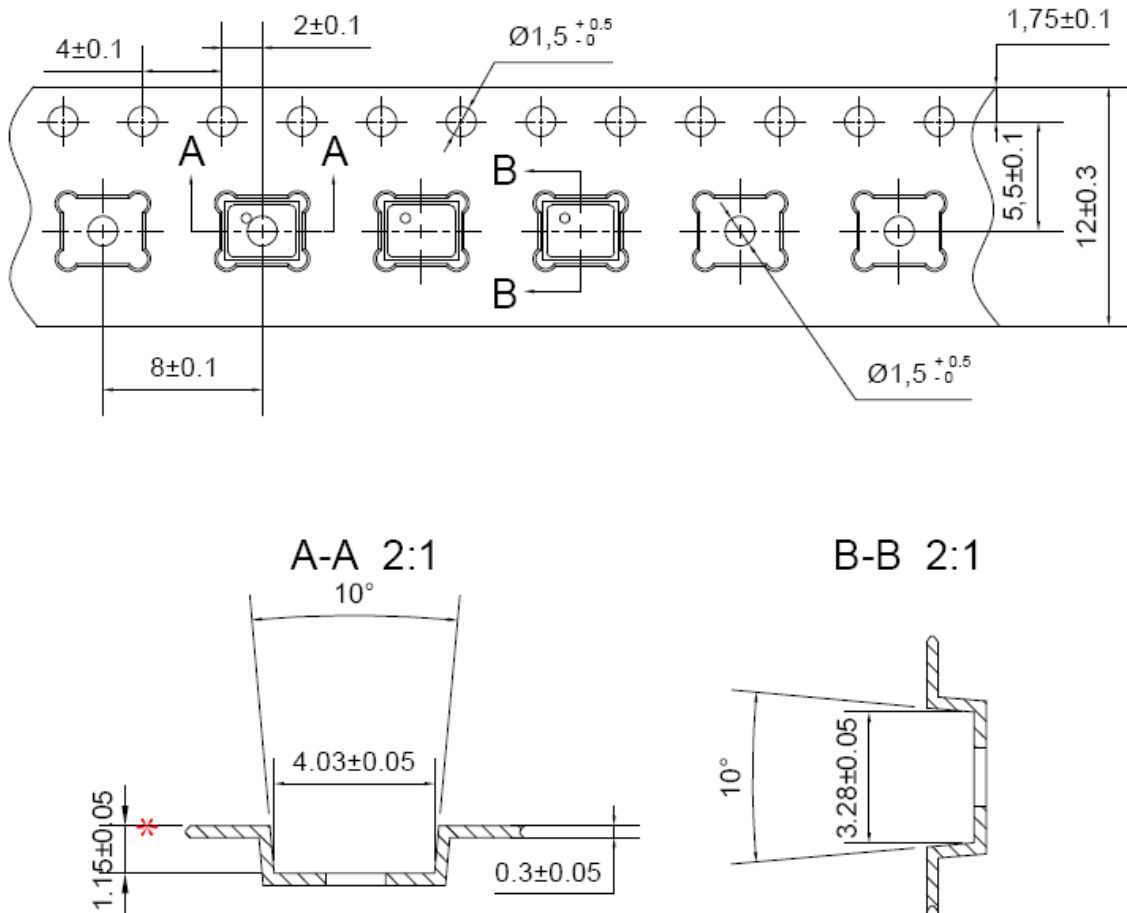

Figure 7: Carrier Tape (1)

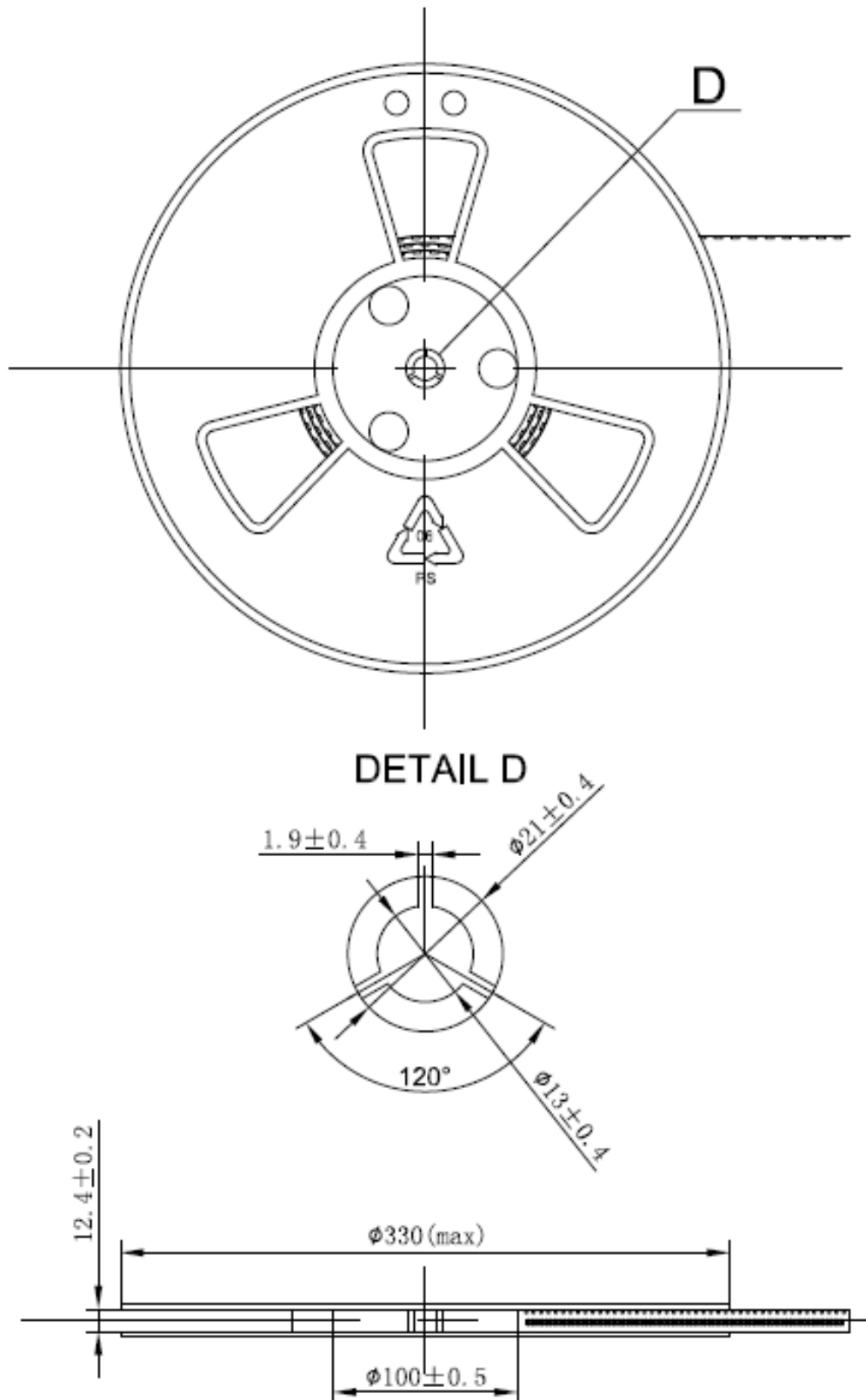

Figure 8: Carrier Tape (2)

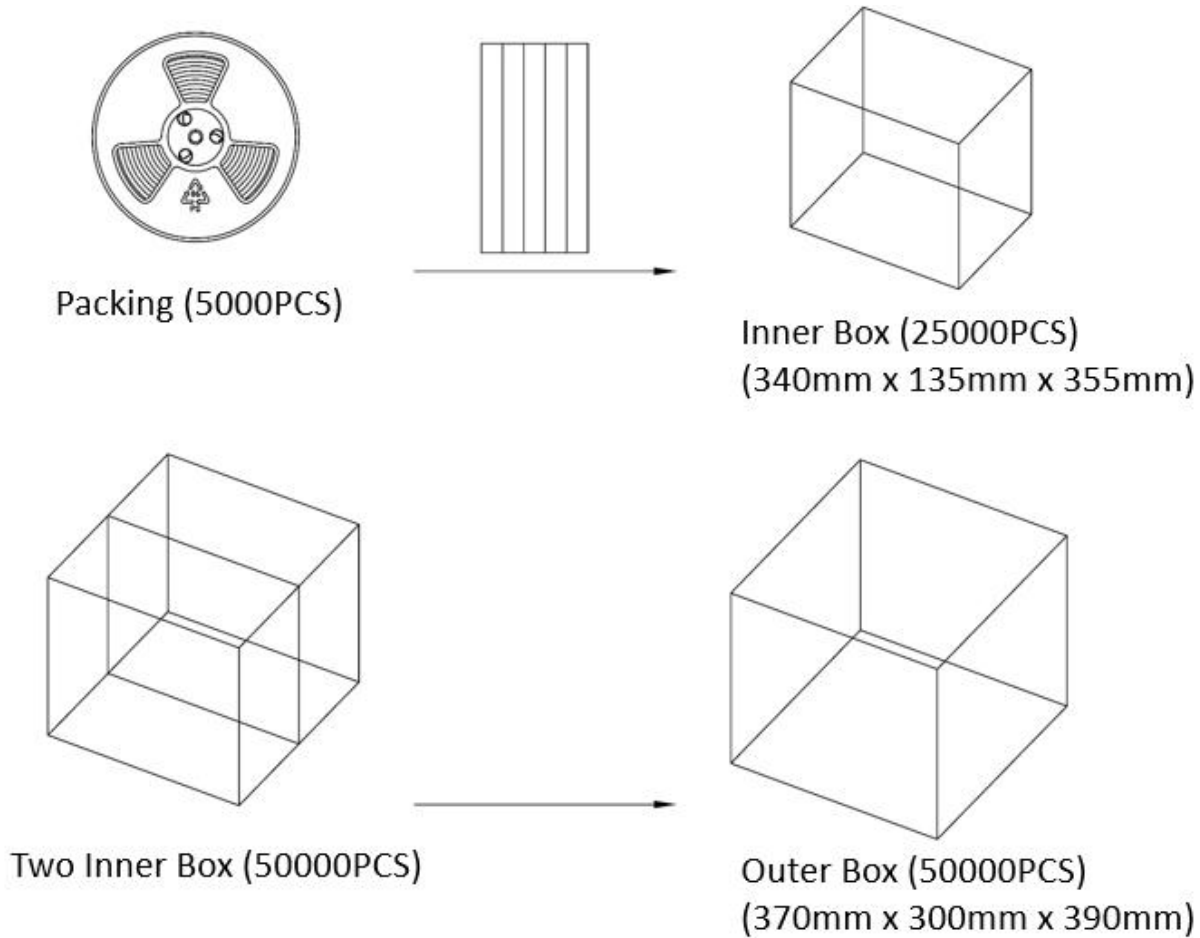

Figure 9: Packing Box